

# Warranty Service Request Form

If you have a warranty claim please contact your MDI Territory Manager. **In order to process your claim, MDI requires photos of the defects at all angles.** Please send this completed form and photos to your MDI salesperson. \* = required field

### Homeowner or Contractor Information

\*Name: \_\_\_\_\_  
 \*Address: \_\_\_\_\_  
 \*City, State, Zip: \_\_\_\_\_  
 \*Phone #: \_\_\_\_\_  
 Email: \_\_\_\_\_  
 \*Complete Description of Job Site Inspection Findings: \_\_\_\_\_

### Dealer Information

\*Name: \_\_\_\_\_  
 \*Location: \_\_\_\_\_  
 \*Email: \_\_\_\_\_  
 \*PO# or MDI Tran#: \_\_\_\_\_  
 \*Product Size/Color/Description: \_\_\_\_\_

MDI will use email as well as phone as communication for service. Emails (when provided) will be used to remind both the homeowner and the dealer of service to occur the day before service is scheduled to arrive. If service is not completed on that date, further communication will follow.

Product that is past 1 year from date of purchase will be repaired at a cost to the homeowner. For labor rates to install warranty parts past 1 year from date of purchase please contact your territory manager. Payment is due from homeowner at time of service.

## Job Site Door Inspection Checklist

**This must be done BEFORE submitting**

### Single or Sidelite Door Application

- \_\_\_ Is the door frame square?
- \_\_\_ Are the margins equal around door?
- \_\_\_ Is the jamb bowed?
- \_\_\_ Are the strike plates and latch adjusted?
- \_\_\_ Are the latch bolts installed flush to the edge of the door?
- \_\_\_ Is the riser bar properly adjusted?
- \_\_\_ Is the sill caulked at ends of riser bar after adjustment?
- \_\_\_ Is there continuous caulk below the sill?
- \_\_\_ Are the corner sill pads installed?
- \_\_\_ Is the weather-strip sealing in corners?
- \_\_\_ Is the door warped and was a string test done?
- \_\_\_ Is the door twisted?

### Double Door Application

- \_\_\_ Are the flush bolts drilled in proper location/door tight to W-strip?
- \_\_\_ Are the bottom flush bolts drilled deep enough in sill?
- \_\_\_ Are the corner sill pads installed on jamb and astragal?

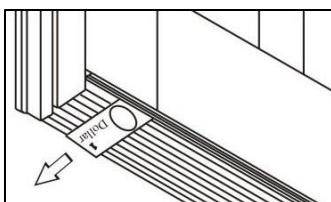
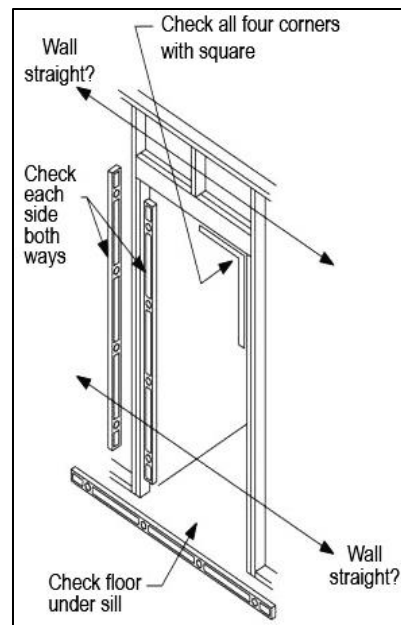
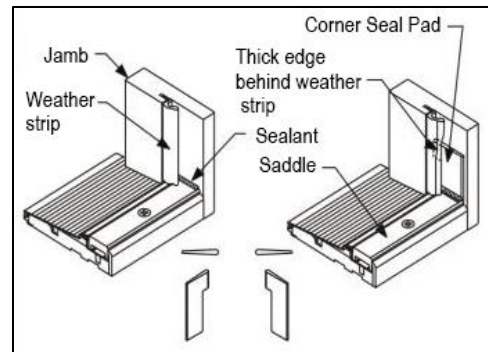

Is riser adjusted and test been done?

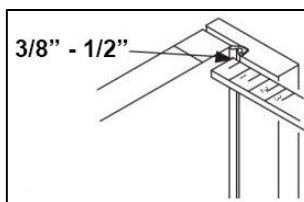

Check margins on both sides of door



MILLWORK DISTRIBUTORS, INC.

---

## WARRANTY SERVICE POLICIES

Product problems may arise during the course of manufacturing, delivery, or installation of MDI products. Prompt and responsive service is the best form of advertising for everyone involved. To this end, Millwork Distributors offers several methods of ensuring customer satisfaction after the sale, creating long term growth and satisfaction in our partnership with our customers.

### **Normal Service and Adjustments**

It is the responsibility of the dealer to make the initial inspection of the affected product to insure the following:

1. Proper product data is collected which is necessary to insure quick response with appropriate material and labor (i.e.: product style, color, age, warranty code, jamb depths, manufacturer, etc.)
2. Verify that product was provided by MDI.
3. Inspect the cause and concern and identify the root of the problem to the best of their ability.

MDI Sales Representation is available to assist in collection of this information with the dealer representative.

Any replacement parts ordered due to manufacturer defect that can be easily installed by homeowner will be shipped direct to dealer at no charge. Replacement parts that are deemed to be above normal gauge of what can be easily installed by homeowner, and are still covered by material warranty as outlined by manufacturer will be installed by MDI service at no charge to homeowner for up to 1 year from date of purchase. This extension of manufacturer warranty is a goodwill offering by MDI. MDI, at its option, may follow "material only" guidelines as specified by manufacturer warranty.

### **Installation Concerns**

Installation concerns noted by dealer and/or MDI Sales Representation are not the responsibility of manufacturer or distributor to correct. MDI, at its option, will make installation corrections to MDI products at the rates as outlined below. These rates will be billed to the dealer or directly to the homeowner and are considered due at the time service is rendered. Billable service will be done as a per quote basis. Please reach out to your territory manager to quote this service. The MDI service quote will include \$1 per mile from MDI to jobsite in the service quoted charge.

### **Materials still within warranty/past 1 year from date of purchase**

Manufacturer defects that fall into this classification (i.e.: 5-year-old seal failure, 8-year-old warped FC panel) are a material only basis as outlined by manufacturer warranty. However, if customer wishes to subcontract MDI Service to install affected part, we will do so at the rates as outlined above. Billing is direct to homeowner and is due at the time service is rendered.

All requests for MDI service must be accompanied by the completed service request form attached. To ensure proper and responsive service to your customer, all requested information on the attached form must be given to MDI Sales Representative or emailed to your MDI Sales Representative.

### **Disclaimer**

MDI warranty service is not to complete or finish an install of any product. If MDI warranty service arrives to the conclusion that the root of the concern is due to an install issue or the lack of following the installation instructions provided by the manufacturer, MDI will be compensated for their time through a per quote basis which will include drive time, service time, and a \$1 per mile charge from MDI to the service site.

***All orders for warranty replacement parts will require inspection of product by your MDI Sales Representative.  
Do not submit no charge warranty service without approval from your MDI Sales Representative.***

---